

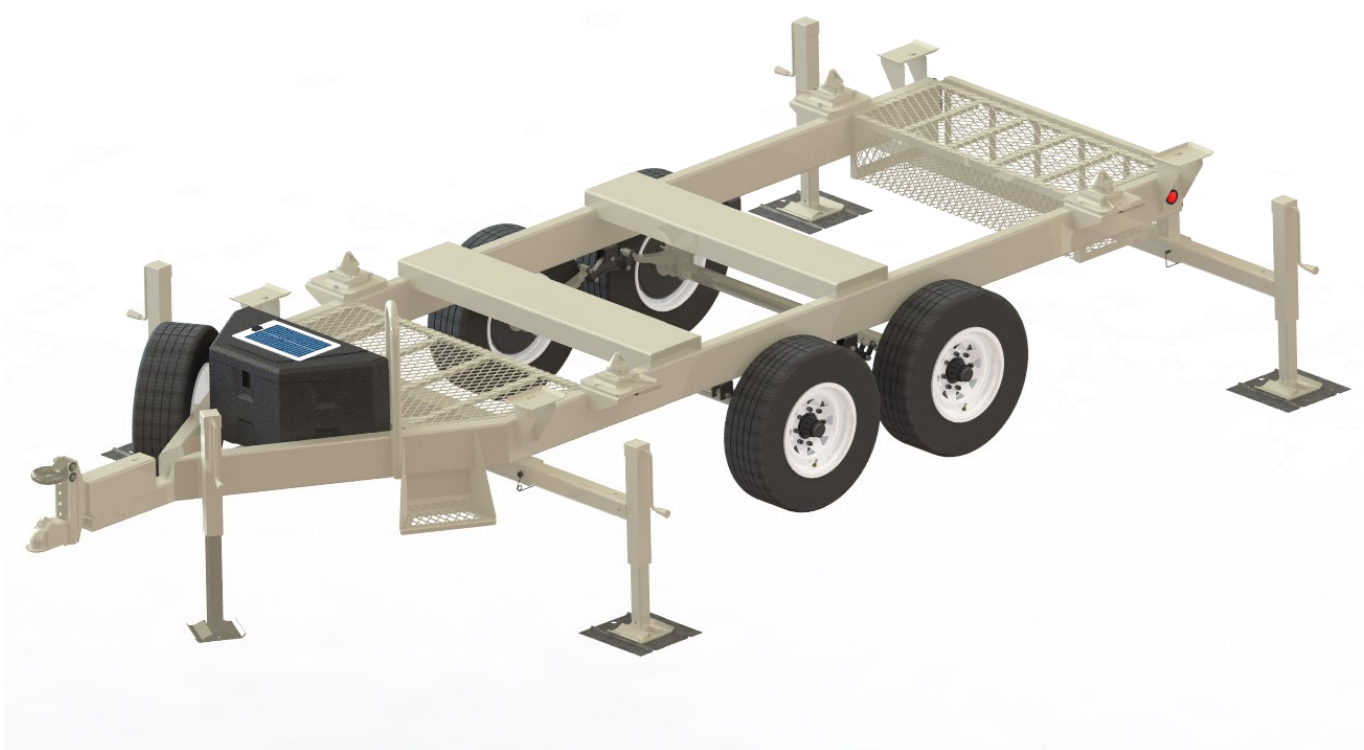

MISSION CONFIGURABLE CONTAINER TRAILER

The MCCS Trailer is the ideal mounting platform for the MCCS. The optional trailer adds 4' of additional height to the container. The outriggers provide superior stability to the MCCS for increased firing accuracy. The MCCS can be easily removed from the trailer when needed by unlocking the twist locks that secure the container to the trailer.

The tool box contains wheel chocks, tire iron, and 16" x 16" rigger plates for additional support on soft surfaces. The 24 VDC solar panel maintains the battery readiness of the MCCS container when in storage.



Part Number	Description	Color	Dimensions	Approx Wt.
10572CS	MCCS (Mission Configurable Container System)	Olive Drab / Desert Tan	10.5' L x 6.5' W x 8' H	8,500 lbs.
10572CT	MCCS Trailer	Olive Drab / Desert Tan	18' L x 7.5' W x 4' H	3,000 lbs.

PERIMETER SECURITY PRODUCTS
 Email: sales@soacorp.com
 265 East Bell Drive, Warsaw, IN
 260-459-0456 (office)
www.perimetersecurityproducts.com



MISSION CONFIGURABLE CONTAINER TRAILER

Product Dimensions:

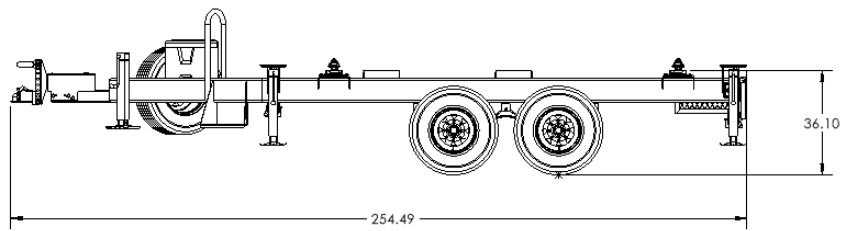
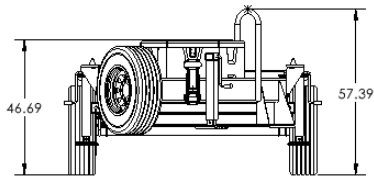
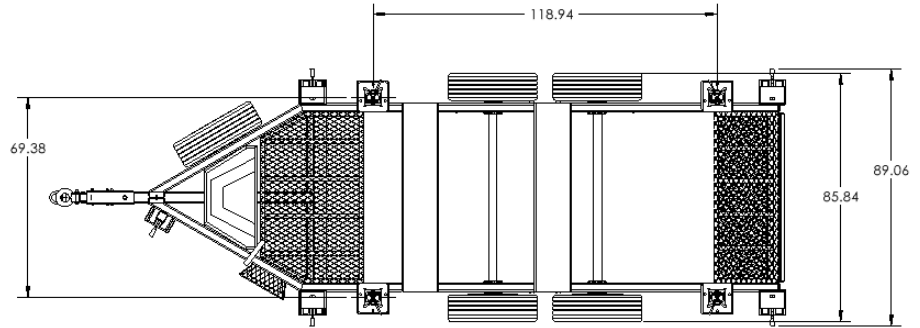

Product Dimensions w/ Outriggers Deployed and MCCS:

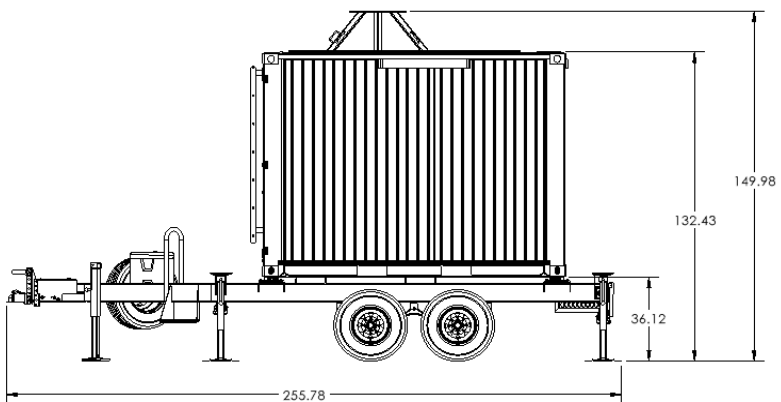
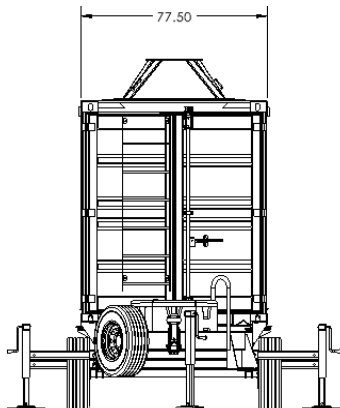
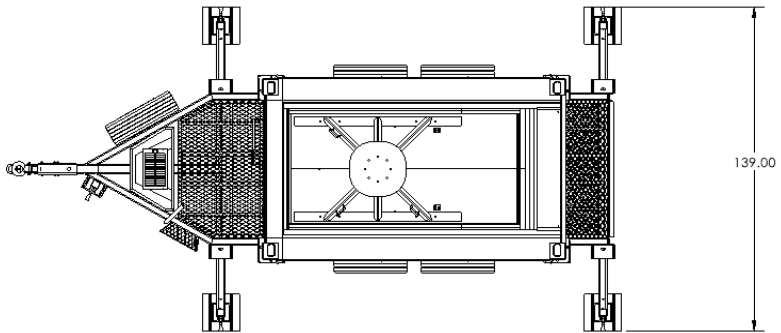

PERIMETER SECURITY PRODUCTS

Email: sales@soacorp.com

265 East Bell Drive, Warsaw, IN

260-459-0456 (office)

www.perimetersecurityproducts.com