



# MISSION CONFIGURABLE CONTAINER SYSTEM

The MCCS is a configurable system that can be rapidly deployed and setup. The MCCS comes equipped with a battery operated pump for raising and lowering the weapon mount platform. The MCCS has a top roof that opens and closes and a weapon platform that locks into place at the top. The MCCS comes configured with an automated system to open the roof, lift the weapon system, and lock the platform in place with a single button press.

## System Specifications:

- Container Size: 10'5" L x 6'5" W x 8' H
- Motorized Retractable Roof
- Automated Operation (can be operated remotely)
- Mount Platform Accommodates 5,000 lbs. Payload
- Internal 24VDC Hydraulic Lift System
- Customizable Platform Mount
- Compatible with Multiple Systems
- Firing Stability
- Inconspicuous: (Looks like a standard shipping container when not deployed)



MCCS shown above deployed with optional 10572CT MCCS Trailer.

The optional trailer adds 4' of additional height to the container. The outriggers provide superior stability to the MCCS making it the ideal platform when deployed. The MCCS can be easily removed from the trailer when needed by unlocking the twist locks that secure the container to the trailer.

Part Number	Description	Color	Dimensions	Approx Wt.
10572CS	MCCS (Mission Configurable Container System)	Olive Drab / Desert Tan	10.5' L x 6.5' W x 8' H	8,500 lbs.
10572CT	MCCS Trailer	Olive Drab / Desert Tan	18' L x 7.5' W x 4' H	3,000 lbs.

## PERIMETER SECURITY PRODUCTS

Email: [sales@soacorp.com](mailto:sales@soacorp.com)  
265 East Bell Drive, Warsaw, IN  
260-459-0456 (office)

[www.perimetersecurityproducts.com](http://www.perimetersecurityproducts.com)



# MISSION CONFIGURABLE CONTAINER SYSTEM

## Product Dimensions:

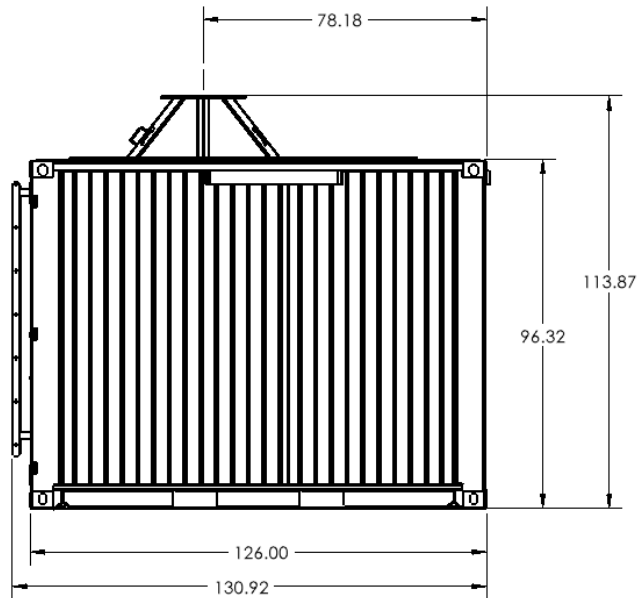
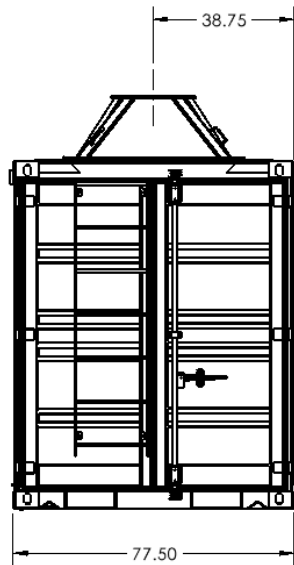
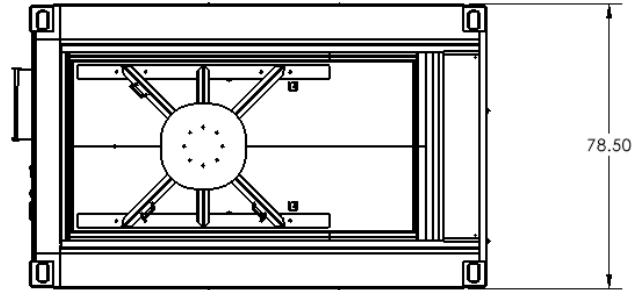

### PERIMETER SECURITY PRODUCTS

Email: [sales@soacorp.com](mailto:sales@soacorp.com)  
265 East Bell Drive, Warsaw, IN  
260-459-0456 (office)

[www.perimetersecurityproducts.com](http://www.perimetersecurityproducts.com)